

# Set-up Instructions

# 1978 Model CR250R



AMERICAN HONDA MOTOR CO., INC.  
100 WEST ALONDRA BOULEVARD, GARDENA, CALIFORNIA 90247

**WARNING**

**WARNING**

**WARNING**

**WARNING**

**SET-UP AND PRE-DELIVERY SERVICE MUST BE PERFORMED BY AN AUTHORIZED HONDA MOTORCYCLE DEALER.** Proper set-up and pre-delivery service is essential to rider safety and reliability of the motorcycle. When a customer takes delivery of his brand new motorcycle, he expects it to be in excellent running condition. There are few things that will cause greater customer dissatisfaction than poor preparation of a new motorcycle. An error or oversight made by the mechanic assembling and servicing a new unit can easily result in faulty operation, damage to the machine, or even injury to the rider.



*NOTE: Right and left are determined from the rider's view.*

# SET-UP INSTRUCTION REVISED PAGES

Pages Affected	Orig. Issue Date	Rev. Date
1 through 24	1/78	Original

**Remove and destroy superseded pages.**

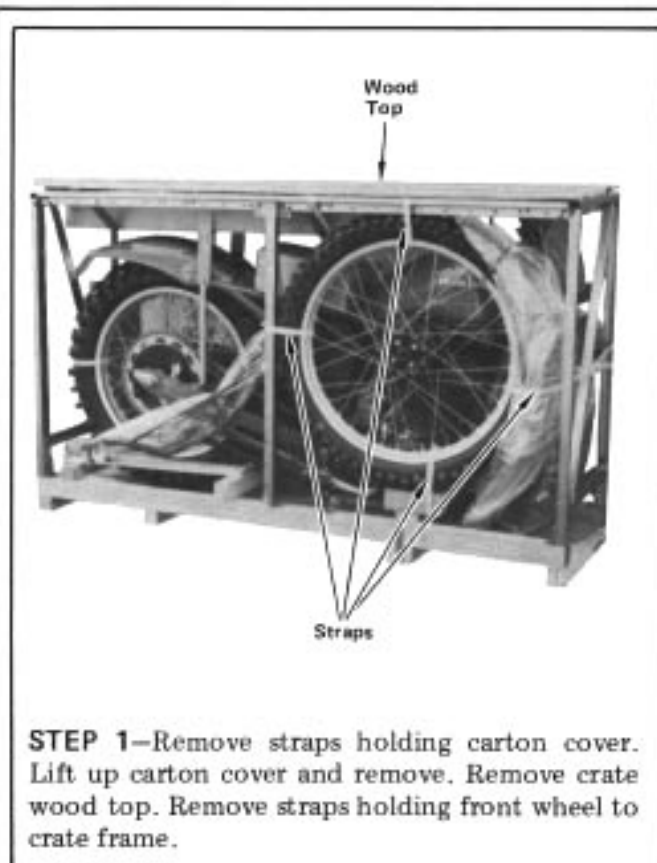

**STEP 1**—Remove straps holding carton cover. Lift up carton cover and remove. Remove crate wood top. Remove straps holding front wheel to crate frame.

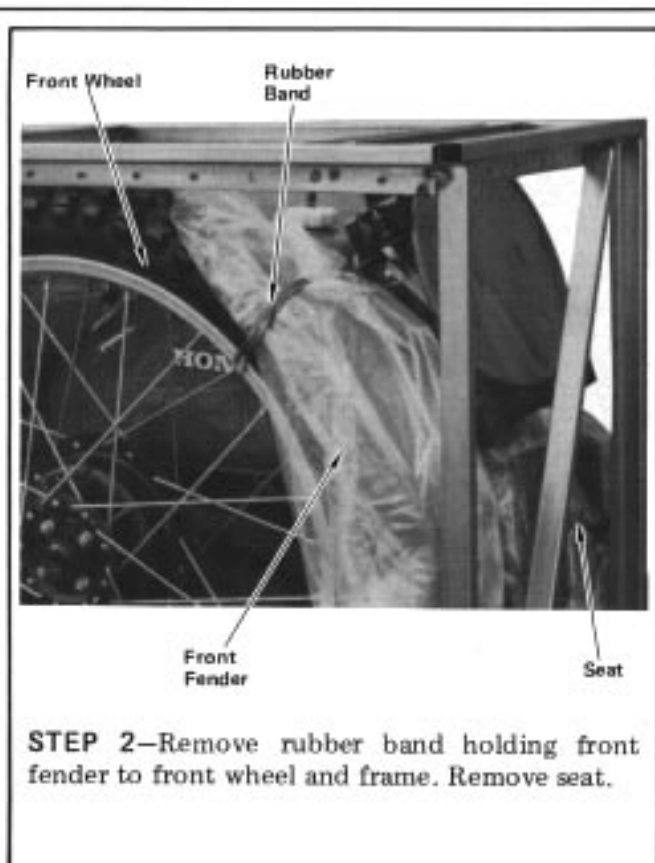

**STEP 2**—Remove rubber band holding front fender to front wheel and frame. Remove seat.

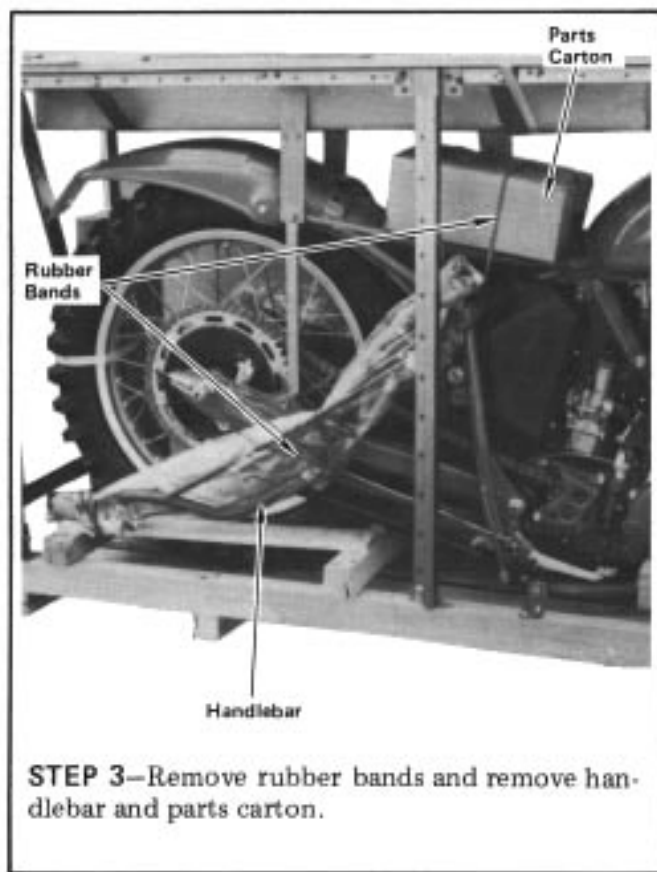

**STEP 3**—Remove rubber bands and remove handlebar and parts carton.

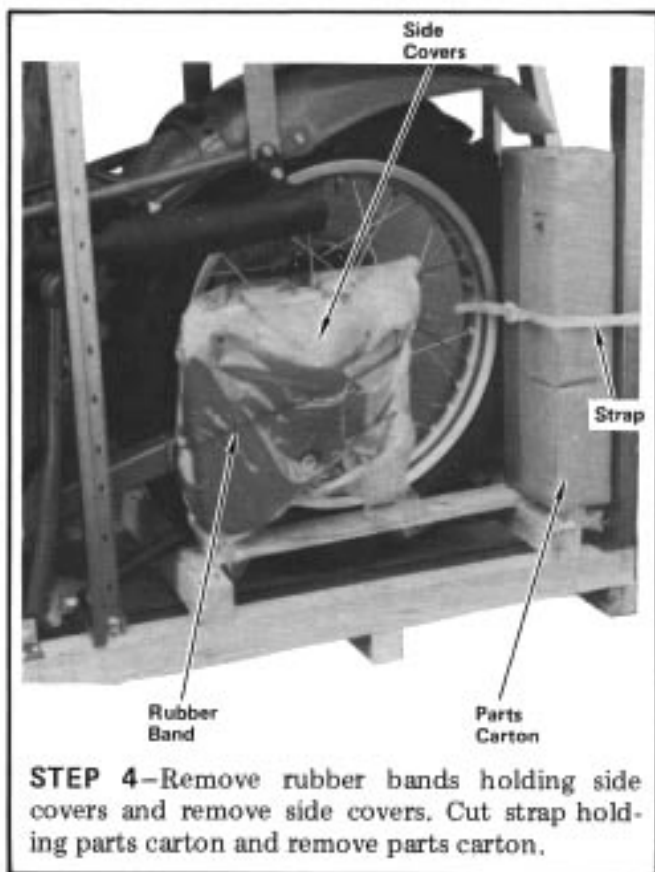

**STEP 4**—Remove rubber bands holding side covers and remove side covers. Cut strap holding parts carton and remove parts carton.

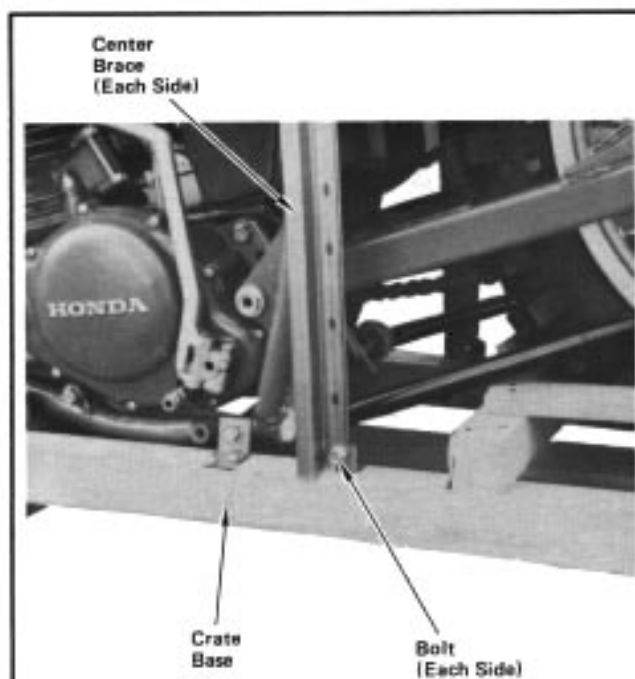

**STEP 5**—Remove two bolts attaching right and left center braces to crate base. Discard bolts and center braces.

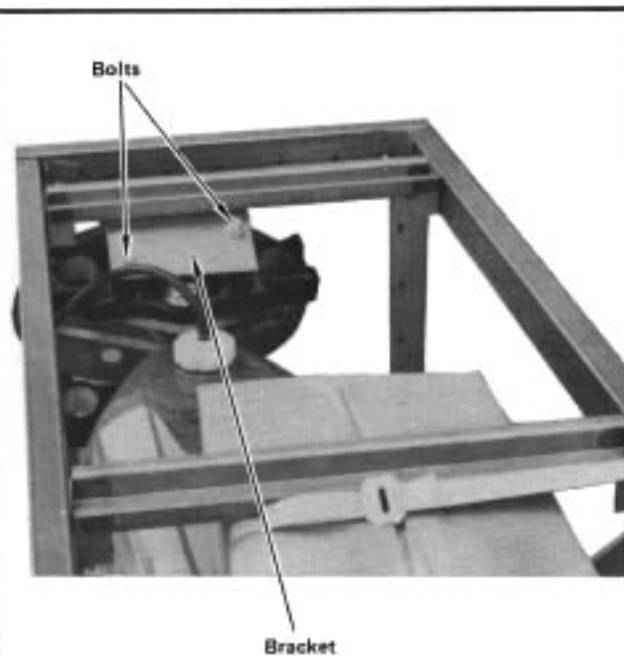

**STEP 6**—Remove two bolts attaching front shipping brace bracket to lower handlebar holders. Discard bolts.

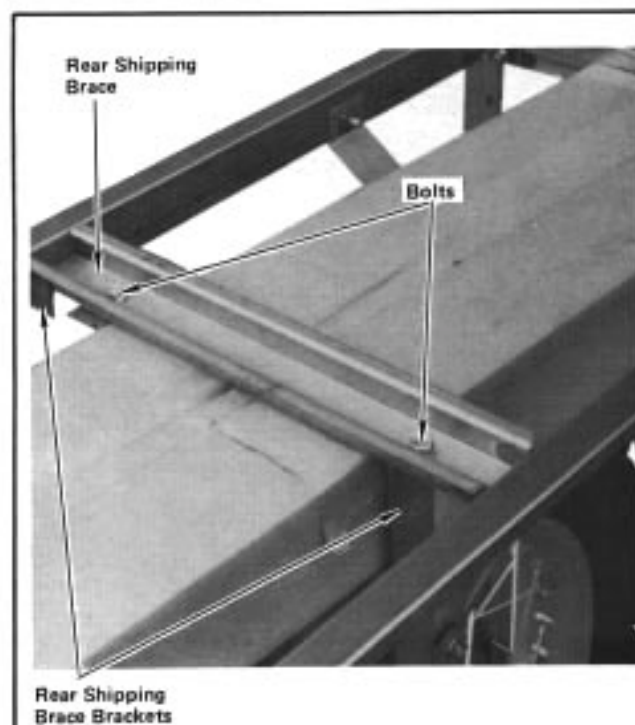

**STEP 7**—Remove two bolts attaching rear shipping brace to rear shipping brace brackets. Discard bolts.

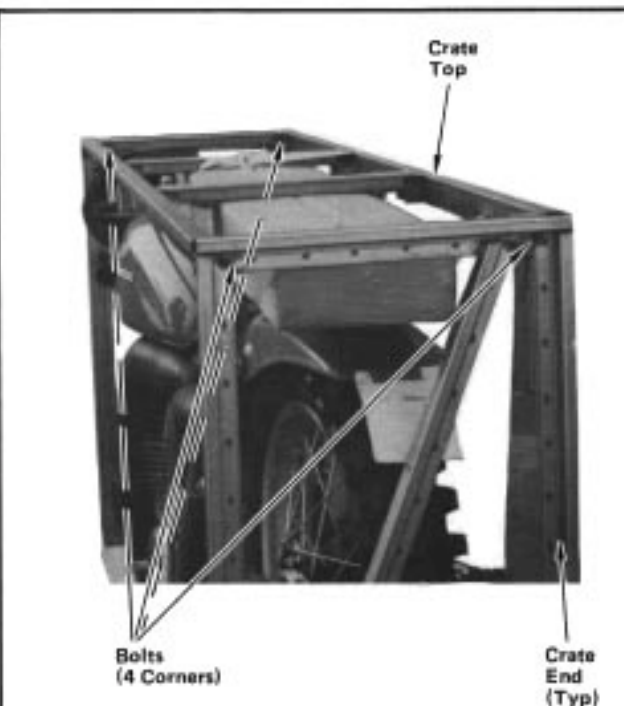

**STEP 8**—Remove four bolts attaching metal crate ends to crate top. Carefully remove crate metal top. Discard bolts.

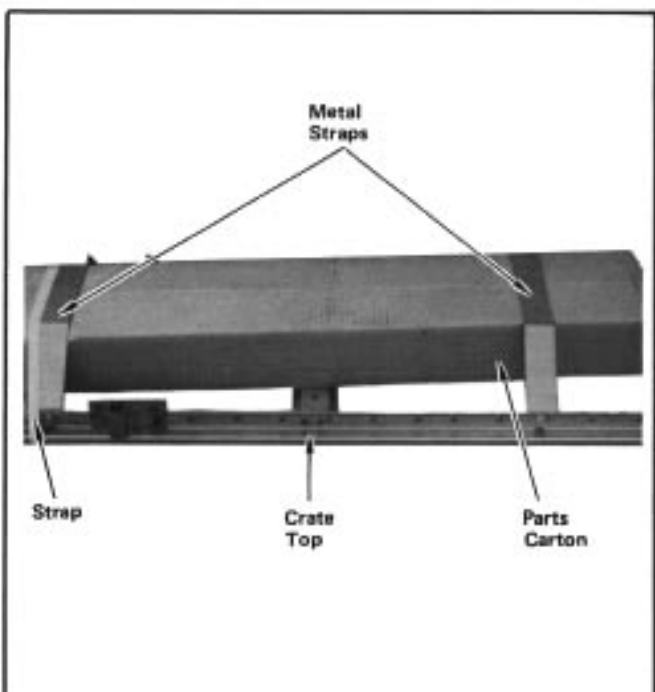

**STEP 9**—Remove bolts attaching metal straps to crate top. Cut strap holding parts carton and remove parts carton. Discard all attaching hardware.

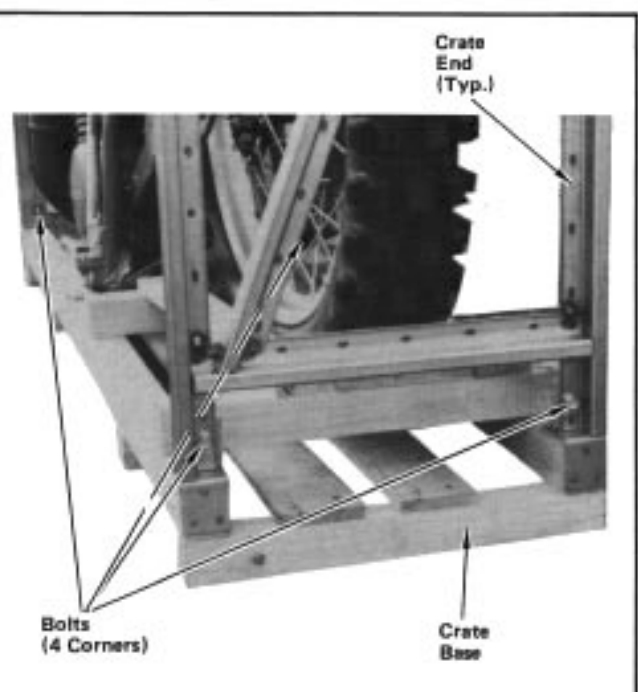

**STEP 10**—Remove four bolts attaching metal crate ends to crate base. Discard bolts and crate ends.

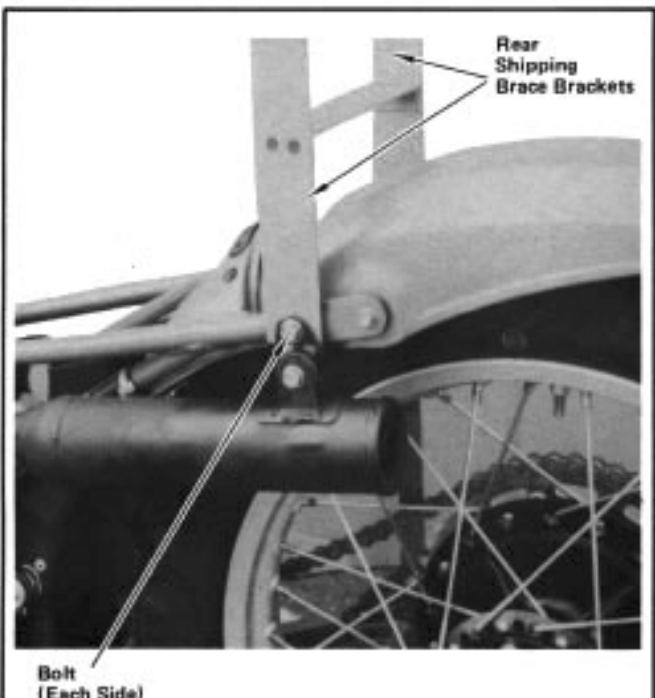

**STEP 11**—Remove rear shipping brace brackets by loosening attaching bolts on each side. Discard brackets.

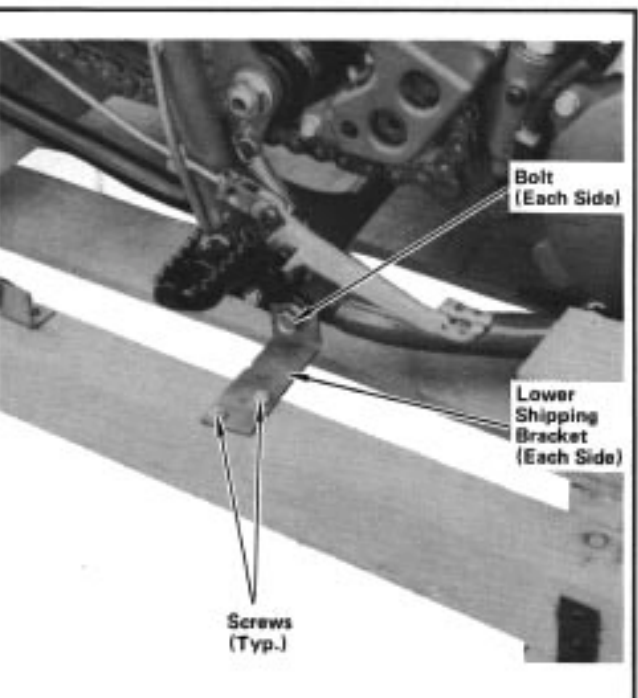

**STEP 12**—Remove lower shipping bracket on each side by removing 10 x 20 mm bolts and screws. Retain bolts for reinstallation and discard screws and brackets.



Front Wheel



Front Fender

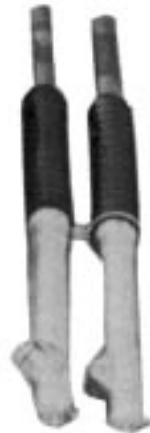

Front Forks



Side Covers



Handlebar



Front Brake Panel Assembly

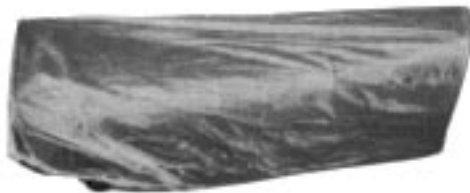

Seat



Throttle Grip Housing



Attaching Hardware



Rear Shock Absorbers



Owner's Manual



Handlebar Upper Holders



Throttle Grip

**STEP 13**—Unpack remaining loose parts and check against this illustration. Report any damaged or missing parts immediately to American Honda Motor Co., Inc., 100 West Alondra Blvd., Gardena, California 90247.

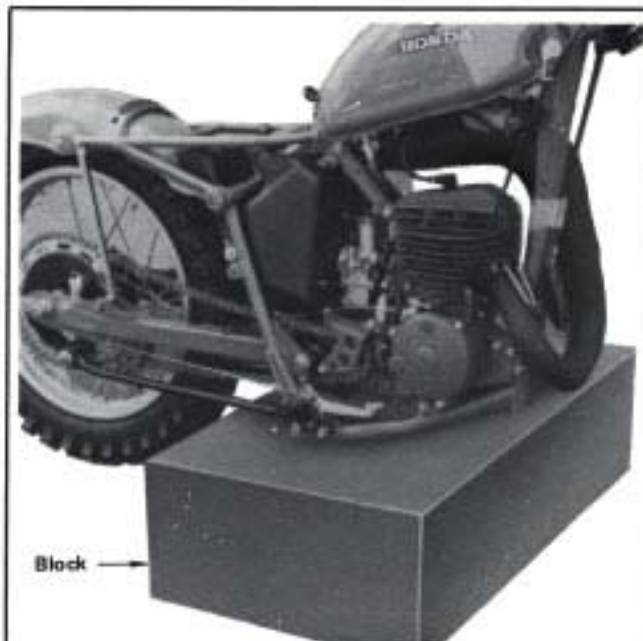

Block

**STEP 14**—Remove motorcycle from crate base and support on a padded block under engine.

**WARNING** Motorcycle can easily be tipped over until it is resting on front wheel and side stand.

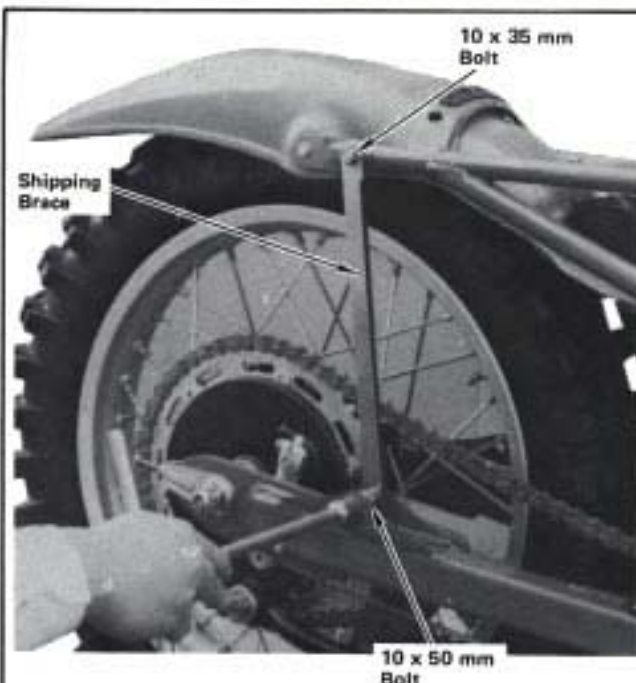

10 x 35 mm Bolt

Shipping Brace

10 x 50 mm Bolt

**STEP 15**—Remove shipping brace from between frame and right swing arm by removing two 10 mm bolts. Retain bolts and discard shipping brace and collar.



Rear Shock Absorber

10 x 35 mm Flange Bolt

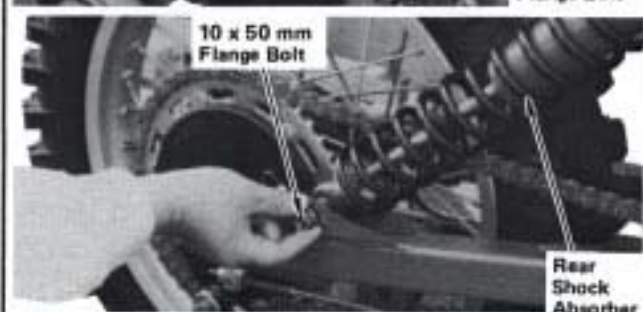

10 x 50 mm Flange Bolt

Rear Shock Absorber

**STEP 16**—Install right rear shock absorber as shown using bolts retained in step 15. Install the 10 x 35 mm flange bolt on the frame end and the 10 x 50 mm flange bolt on the swing arm end.

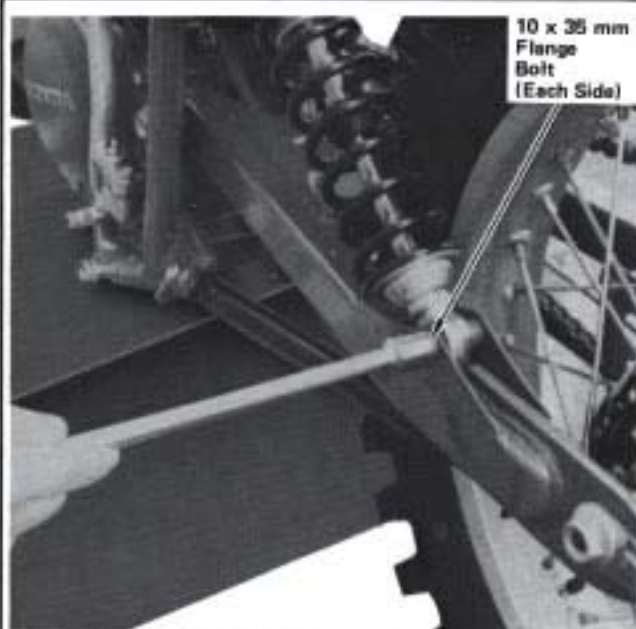

10 x 35 mm Flange Bolt (Each Side)

**STEP 17**—Install left rear shock absorber as shown using two 10 x 35 mm flange bolts. Tighten all four shock absorber attaching bolts to specified torque.

**Torque specification:**

3.8–4.8 kg-m (28–35 lbs-ft)



**STEP 18**—Slide right fork leg (fork leg with split boss) up through upper and lower fork bridges, aligning top of fork leg with top of upper fork bridge.



**STEP 19**—Insert two 8 x 40 mm flange bolts through holes in lower fork bridge as shown. Tighten bolts to specified torque.

**Torque specification:**  
1.8–2.5 kg-m (13–18 lbs-ft)

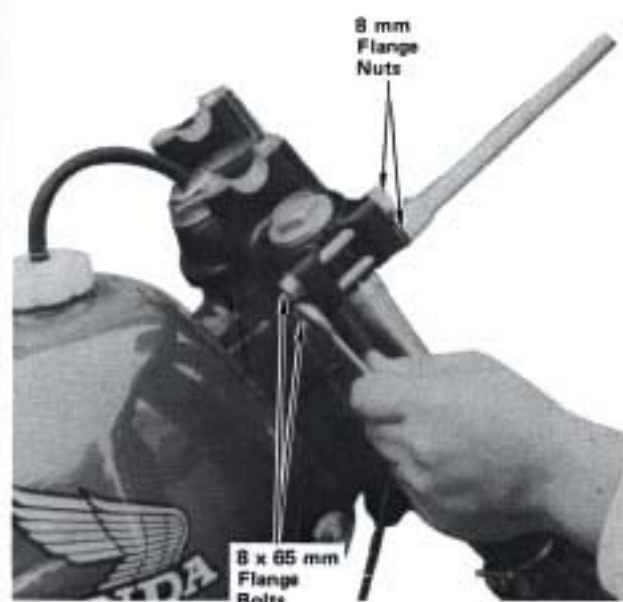

**STEP 20**—Insert two 8 x 65 mm flange bolts through holes in upper fork bridge from the rear, and install two 8 mm flange nuts. Tighten nuts to specified torque.

**Torque specification:**  
1.8–2.5 kg-m (13–18 lbs-ft)

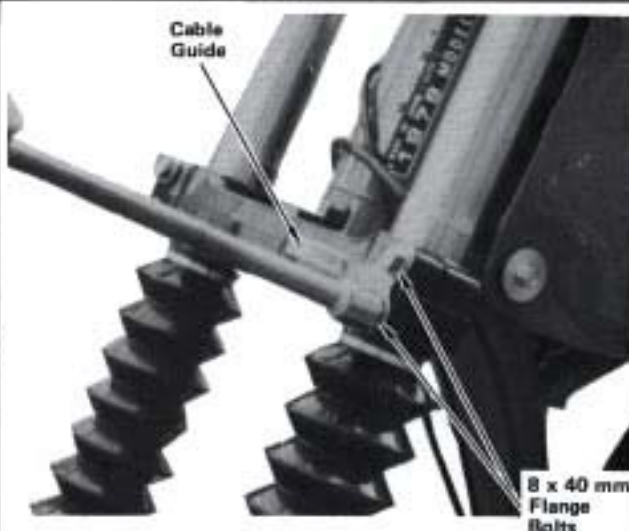

**STEP 21**—Slide left fork leg up through upper and lower fork bridges, aligning top of fork leg with top of upper fork bridge. Position cable guide as shown and insert two 8 x 40 mm flange bolts through cable guide and into holes in lower fork bridge. Tighten bolts to specified torque.

**Torque specification:**  
1.8–2.5 kg-m (13–18 lbs-ft)



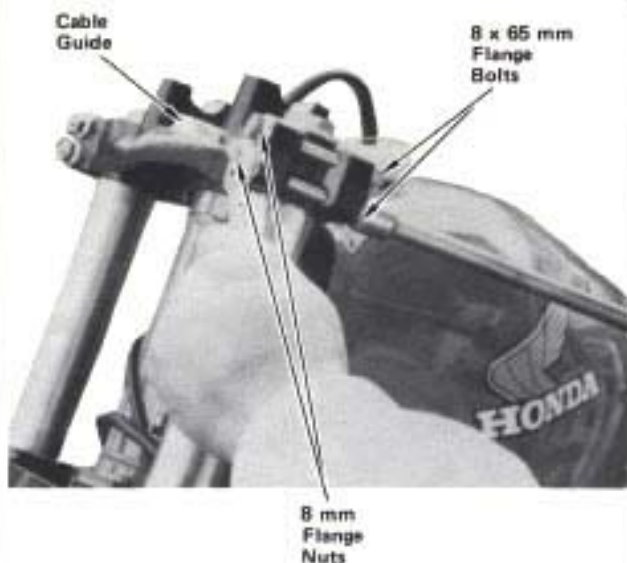

**STEP 22**—Position cable guide as shown and insert two 8 x 65 mm flange bolts through holes in upper fork bridge and cable guide, from the rear. Install two 8 mm flange nuts and tighten to specified torque.

**Torque specification:**

1.8–2.5 kg-m (13–18 lbs-ft)

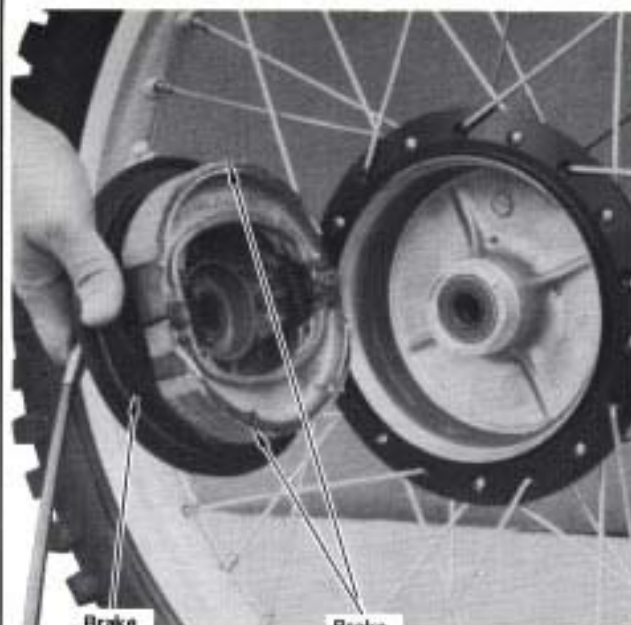

**STEP 23**—Make sure brake linings and inside of brake drum are clean. Clean if necessary, and install brake panel assembly in brake drum. Check that grease seal is clean and filled with grease.

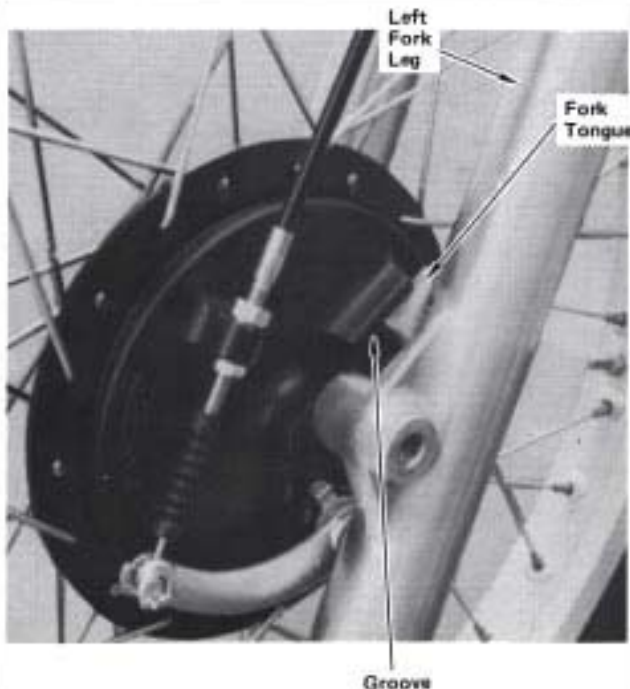

**STEP 24**—Position front wheel between fork legs, with groove in brake panel aligned with tongue on left fork leg.

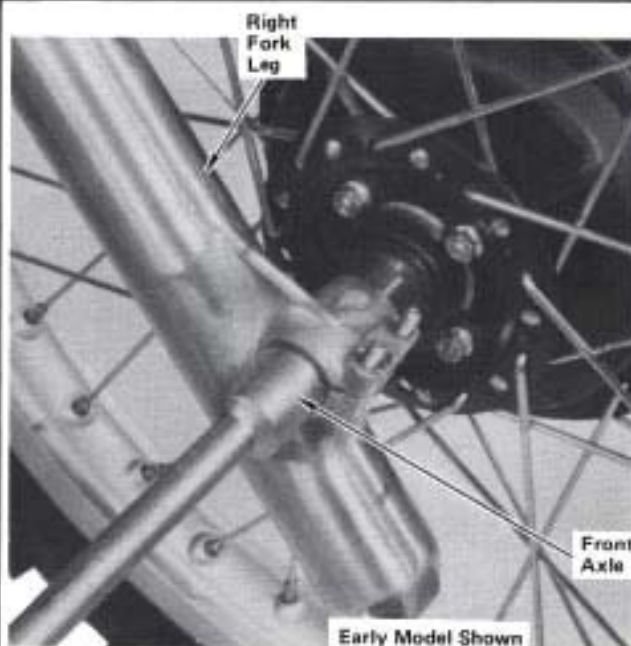

**STEP 25**—Insert front axle through right fork leg, through wheel hub, and thread into left fork leg. Tighten axle to specified torque.

**Torque specification:**

5.5–7.0 kg-m (40–51 lbs-ft)

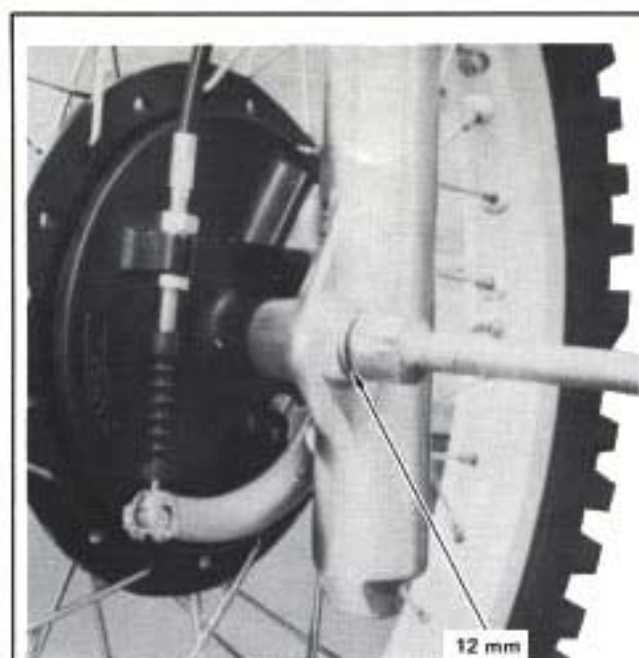
12 mm  
Flange  
Nut

**STEP 26**—Install 12 mm flange axle nut and tighten to specified torque.

**Torque specification:**

5.5–7.0 kg-m (40–51 lbs-ft)

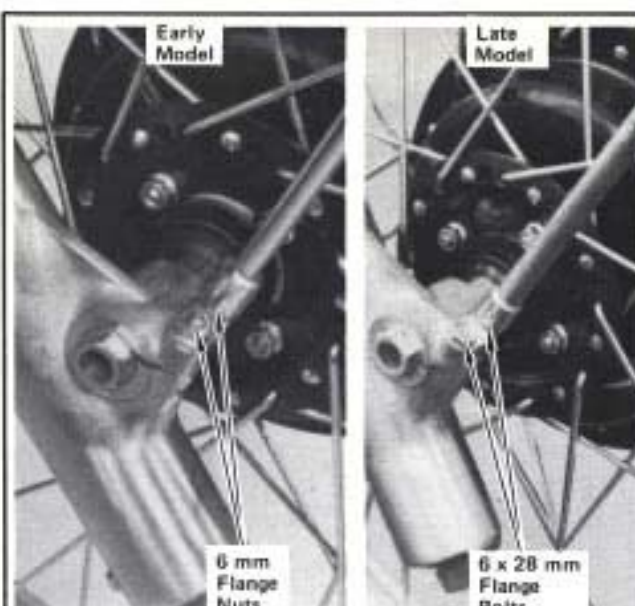
6 mm  
Flange  
Nuts6 x 28 mm  
Flange  
Bolts

**STEP 27**—On early models, install two 6 mm flange nuts on studs on right fork leg. On late models, install two 6 x 28 mm flange bolts in right fork leg. Tighten nuts or bolts to specified torque.

**Torque specification:**

0.8–1.2 kg-m (6–9 lbs-ft)

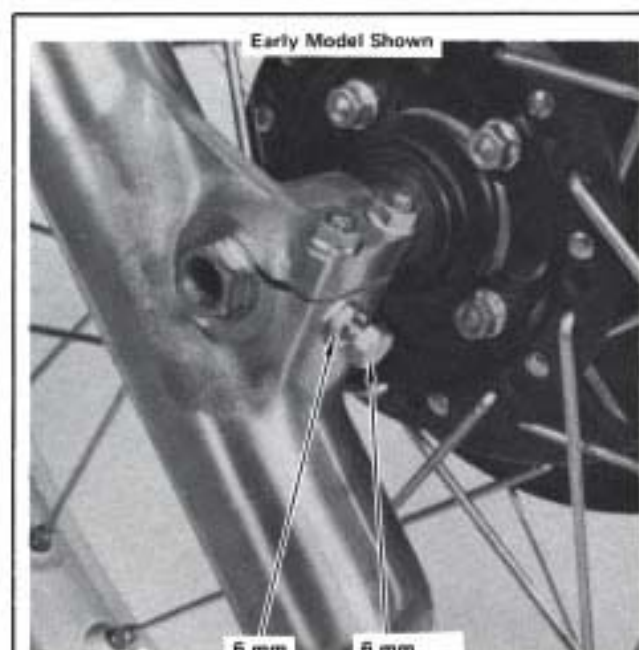
6 mm  
Lock  
Nut6 mm  
Lock Bolt

**STEP 28**—Install 6 mm lock bolt. Tighten bolt to specified torque, then tighten lock nut.

**Torque specification:**

0.8–1.2 kg-m (6–9 lbs-ft)

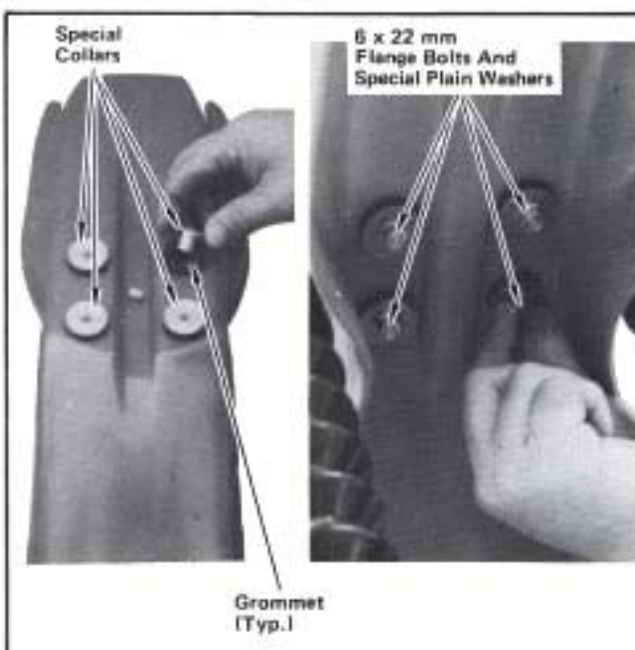
Special  
Collars6 x 22 mm  
Flange Bolts And  
Special Plain WashersGrommet  
(Typ.)

**STEP 29**—Insert four special collars into top of grommets in front fender as shown. Position front fender between fork legs with long end forward and install using four special plain washers and 6 x 22 mm flange bolts. Tighten securely.

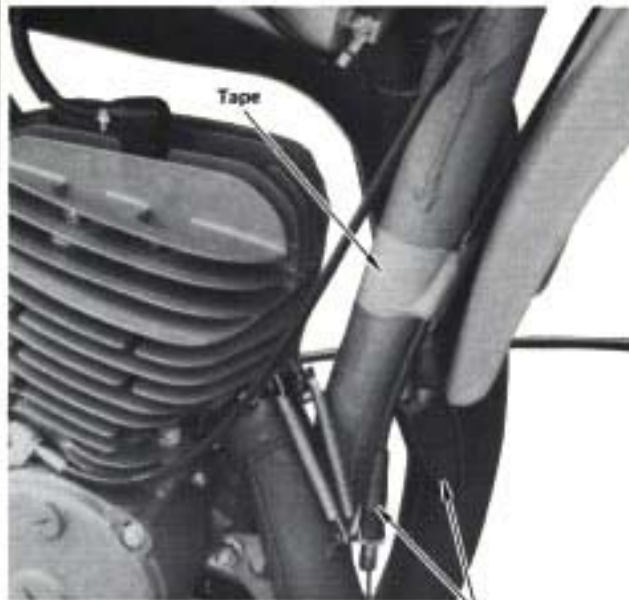

Throttle And  
Clutch Cables

**STEP 30**—Remove tape holding throttle and clutch cables to frame. Route cables forward between right fork leg and steering head, and between upper and lower fork bridges.

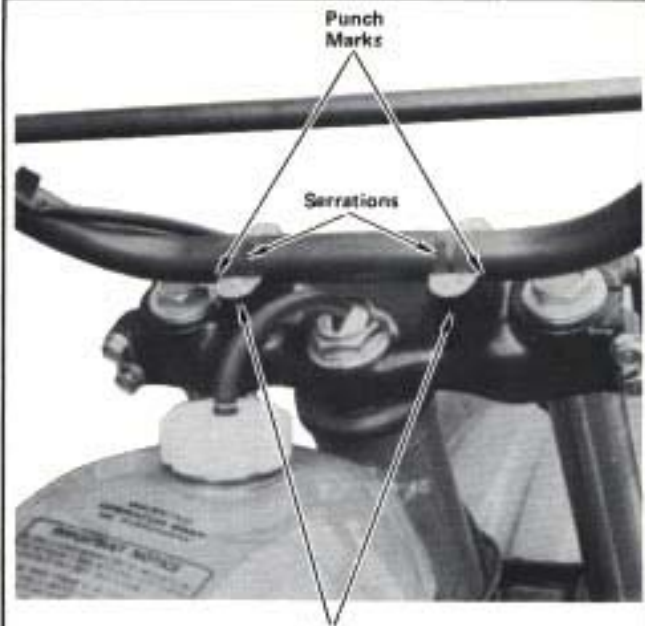

Lower  
Holders

**STEP 31**—Position handlebar on lower holders with serrations aligned with holders and punch marks on handlebar in line with top of holders.

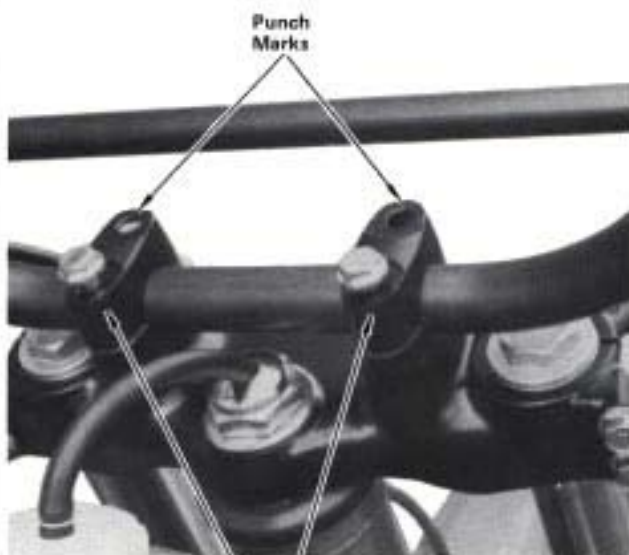

Upper  
Holders

**STEP 32**—Position upper holders on handlebar with punch marks on holders forward.

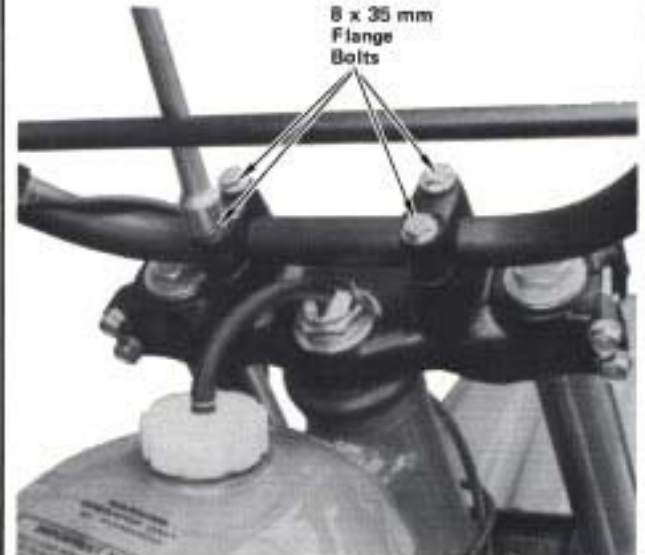

8 x 35 mm  
Flange  
Bolts

**STEP 33**—Install holders loosely using two 8 x 35 mm flange bolts for each. Position handlebar to suit rider and tighten forward bolts to specified torque first, then tighten rear bolts to same torque.

**Torque specification:**

1.8–2.5 kg-m (13–18 lbs-ft)

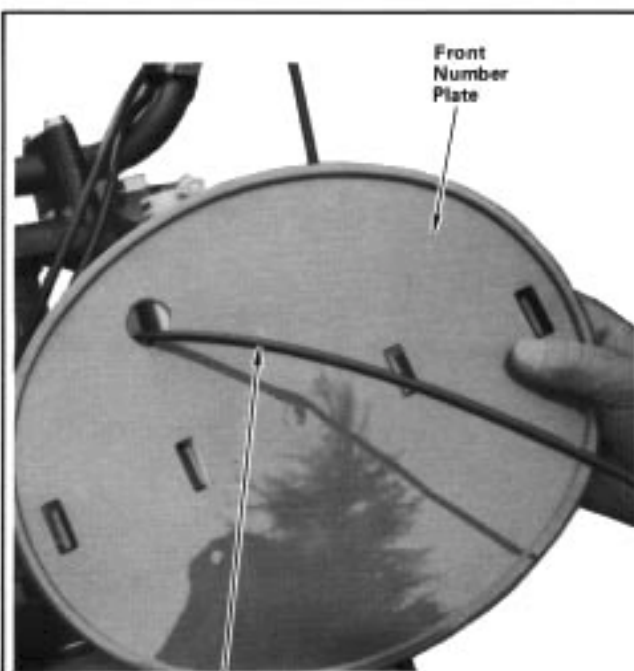

Throttle  
Cable

**STEP 34**—Position front number plate as shown and route throttle cable through round hole in number plate.

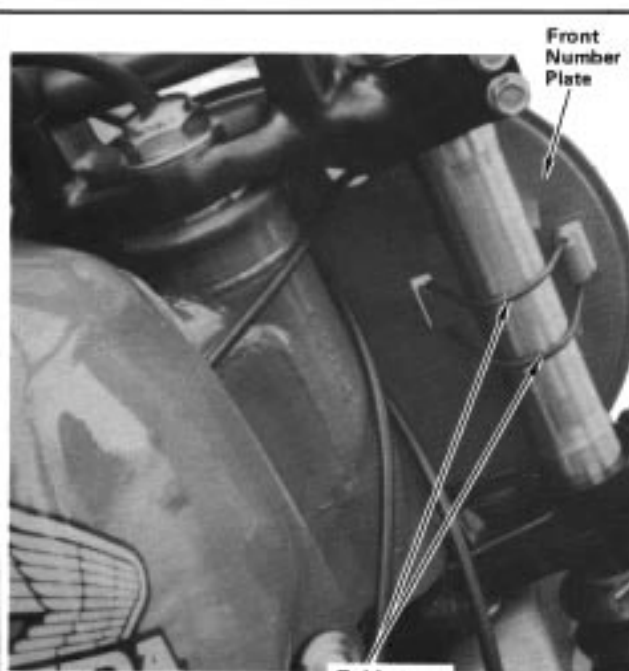

Rubber  
Band  
(Each Side)

**STEP 35**—Hook number plate to fork legs as shown using two rubber bands.

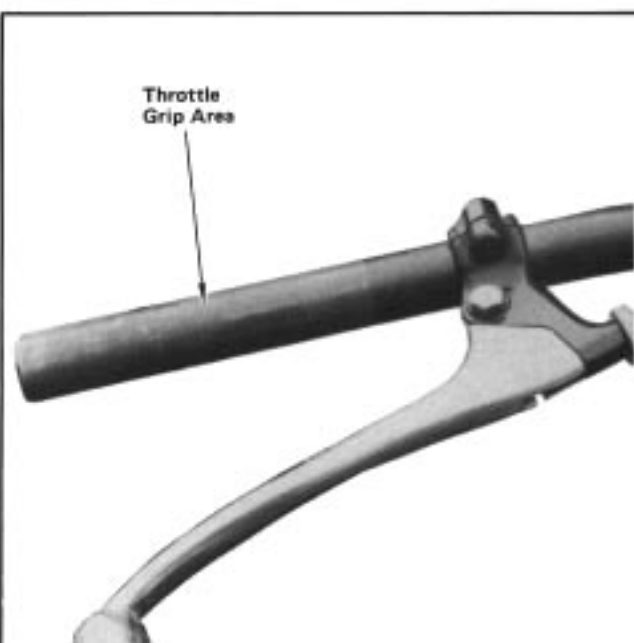

Throttle  
Grip Area

**STEP 36**—Clean throttle grip attaching surface of handlebar and apply a thin coat of clean grease to throttle grip area.

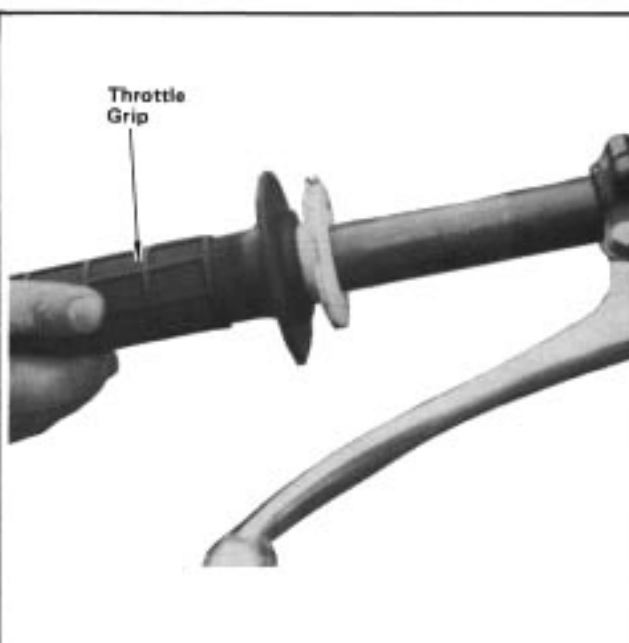

Throttle  
Grip

**STEP 37**—Slip throttle grip onto handlebar.

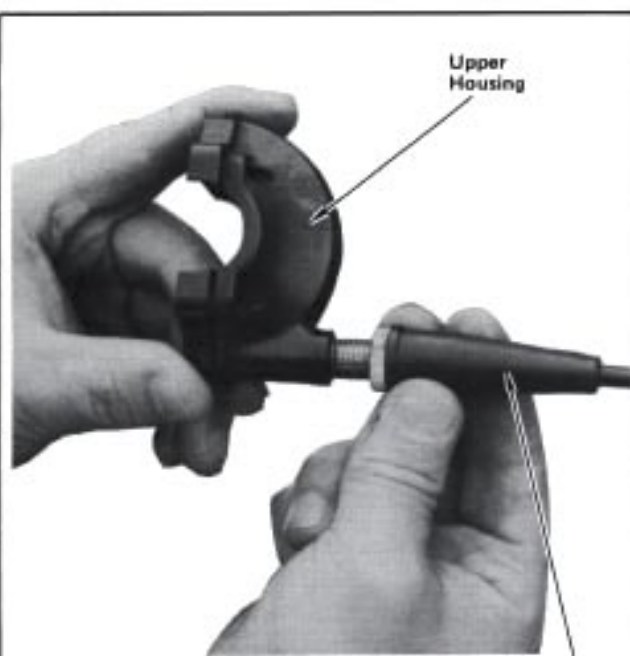

**STEP 38**—Screw throttle cable into upper throttle grip housing and tighten with pliers.

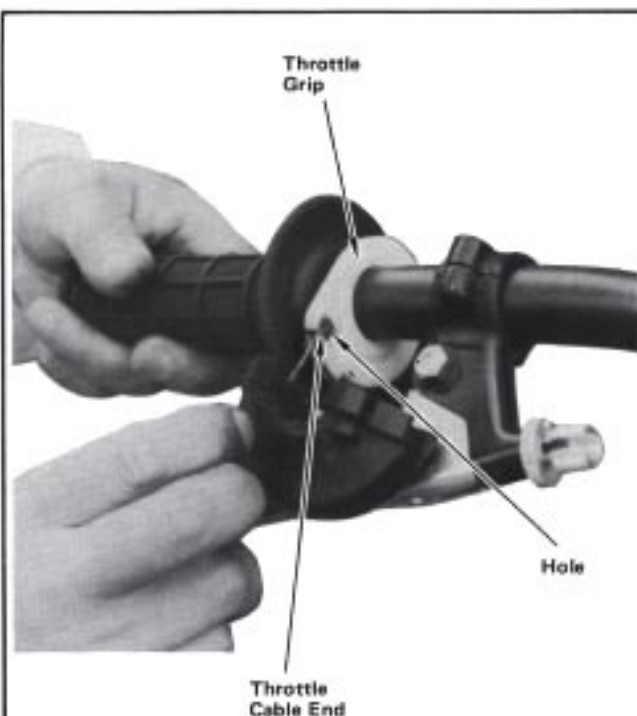

**STEP 39**—Insert end of throttle cable into hole in throttle grip.

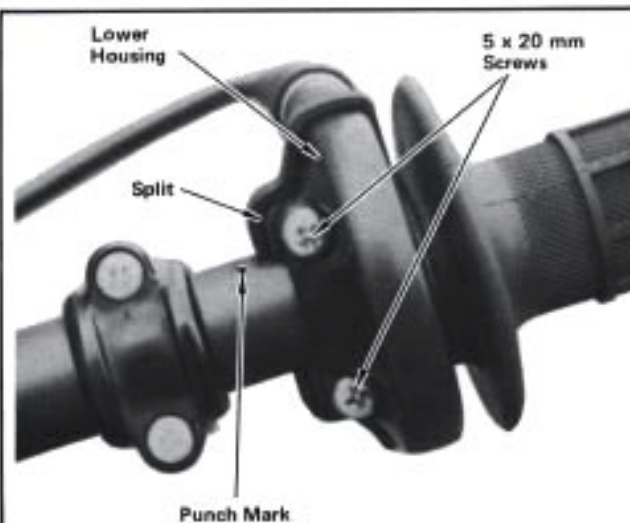

**STEP 40**—Position lower throttle grip housing over throttle grip and assemble using two 5 x 20 mm pan head screws. Align split of housing with punch mark on handlebar. Tighten lower screw to specified torque first, then tighten upper screw to same torque.

**Torque specification:**

0.45–0.60 kg-m (3–4 lbs-ft)

Check that throttle grip turns freely.



**STEP 41**—Remove dust cover from end of front brake cable. Retain for reinstallation.

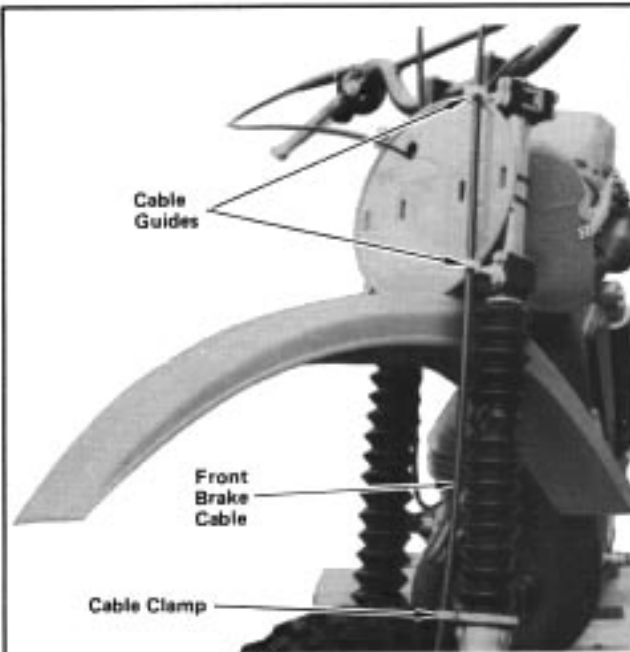

**STEP 42**—Route front brake cable as shown, up through cable clamp on left fork leg, and through cable guides on fork bridges in front of number plate.

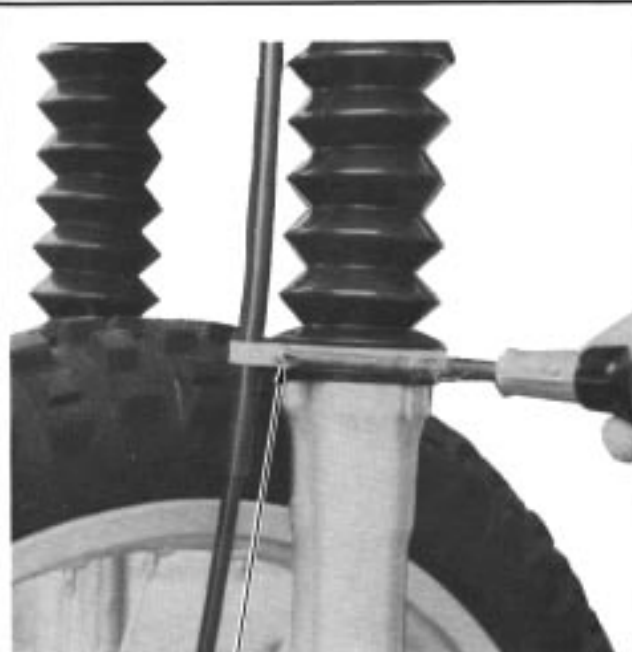

**STEP 43**—Tighten screw of front brake clamp securely.

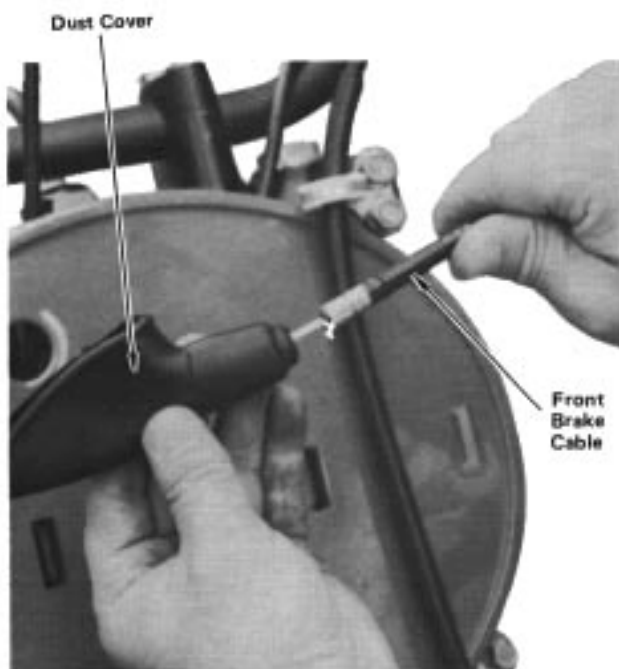

**STEP 44**—Route end of front brake cable through dust cover removed in step 41.

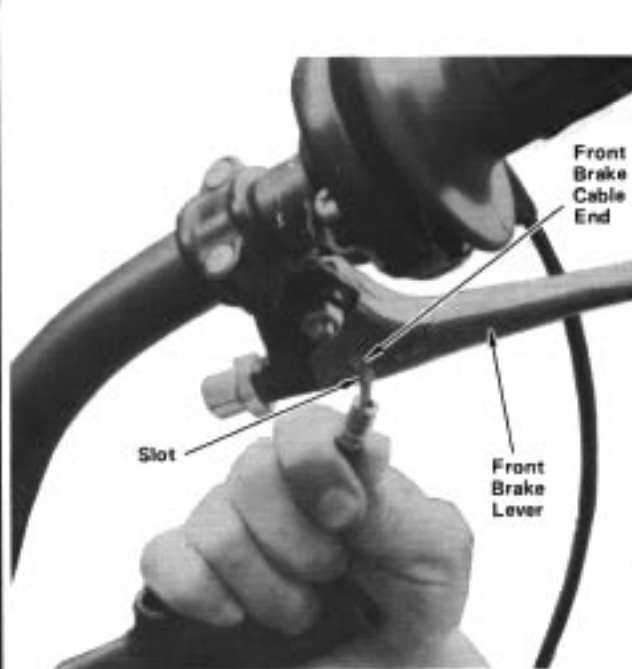

**STEP 45**—Insert end of front brake cable into slot in brake lever.

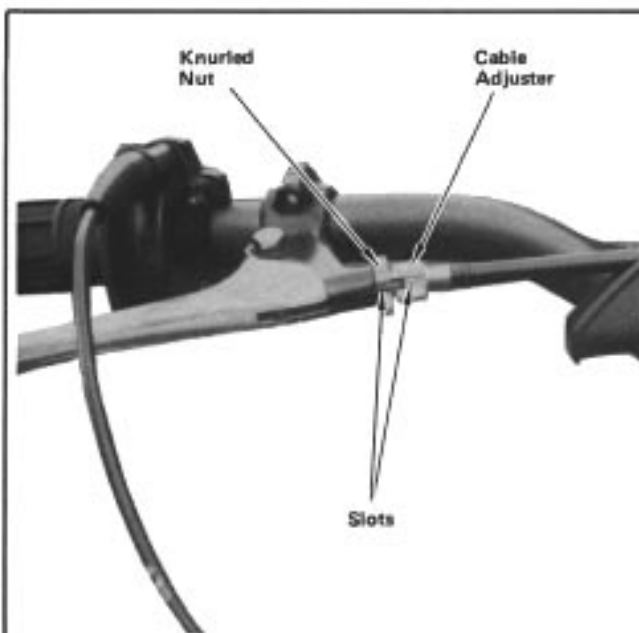

**STEP 46**—Pull brake cable back through slots in knurled nut and cable adjuster.

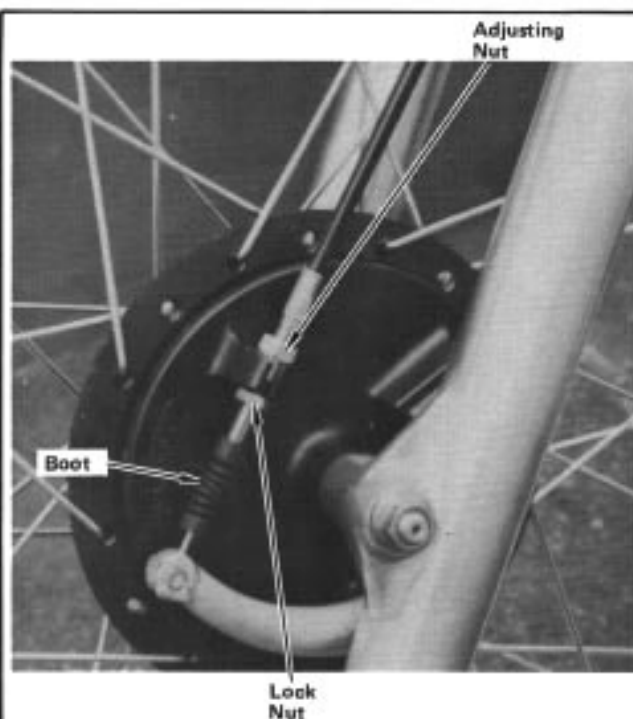

**STEP 47**—Adjust front brake as described in owner's manual and slip rubber boot up over threads. Tighten lock nut.

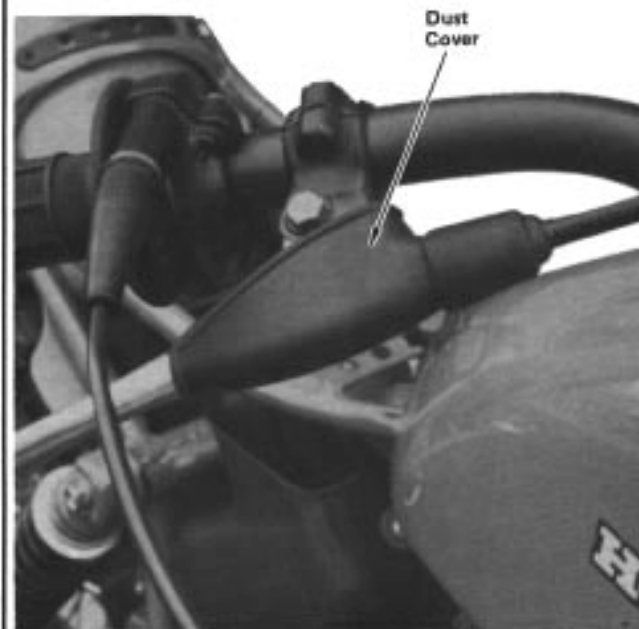

**STEP 48**—Check that front brake lever free play is 10–20 mm (0.4–0.8 in.) at tip of brake lever. If necessary, adjust free play as described in owner's manual. Install dust cover.

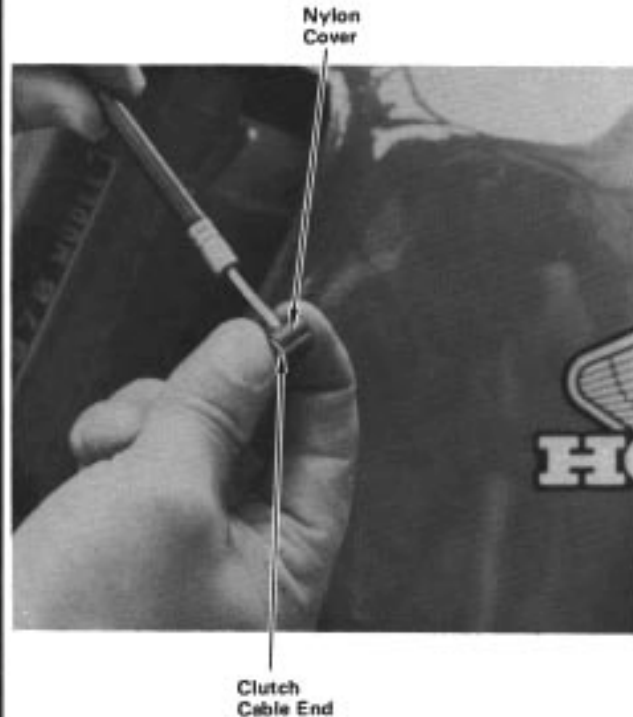

**STEP 49**—Check that nylon cover is over end of clutch cable.

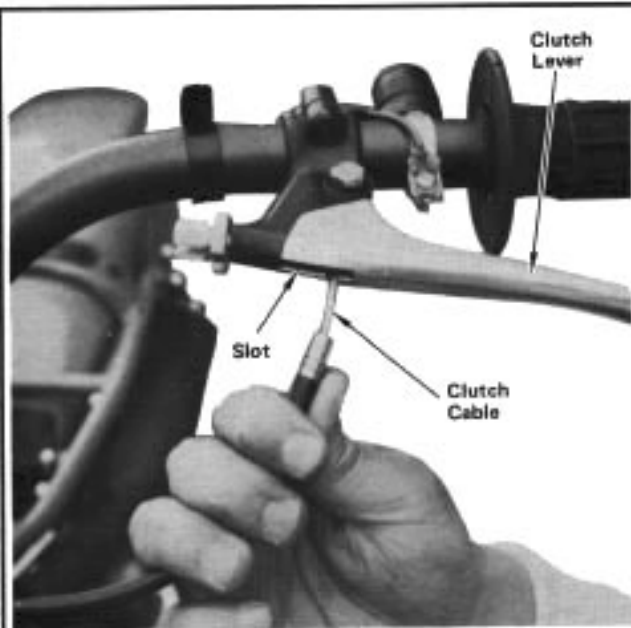

**STEP 50**—Route clutch cable to the rear of the front brake cable and insert end of clutch cable into slot in clutch lever.

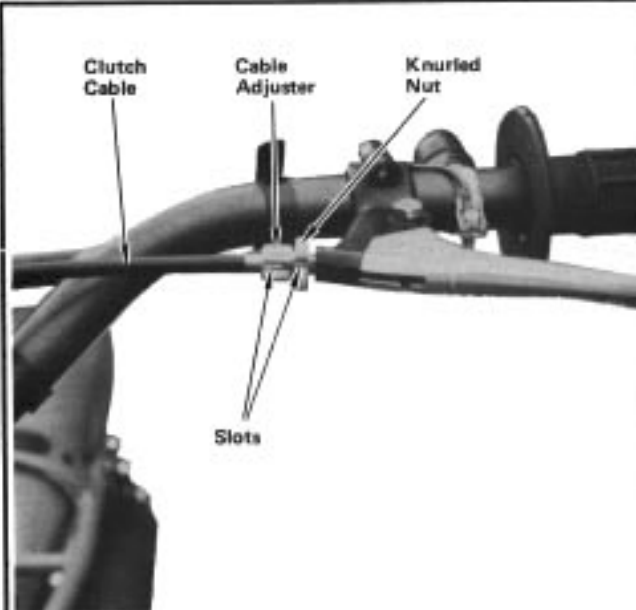

**STEP 51**—Pull clutch cable back through slots in knurled nut and cable adjuster.

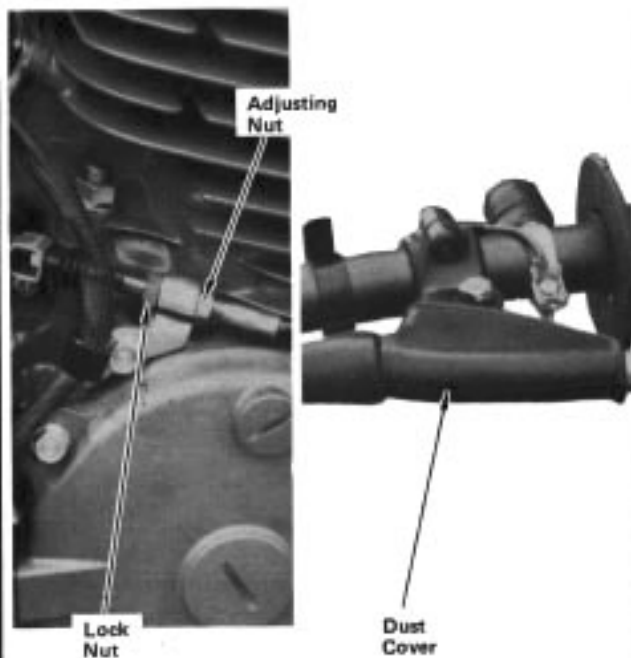

**STEP 52**—Check that clutch lever free play is 10–20 mm (0.4–0.8 in.) at tip of clutch lever. If necessary, adjust free play as described in owner's manual. Install dust cover.

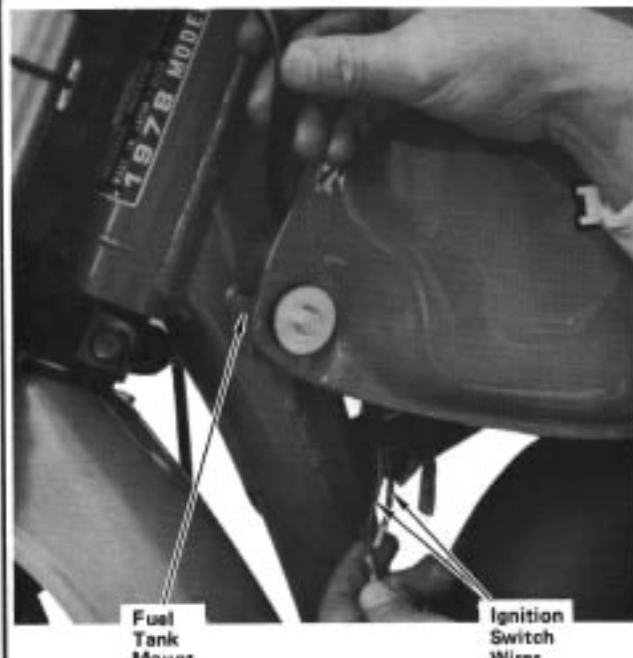

**STEP 53**—Route ignition switch wires above left fuel tank mount between fuel tank and frame. Press wires into space between fuel tank and frame.



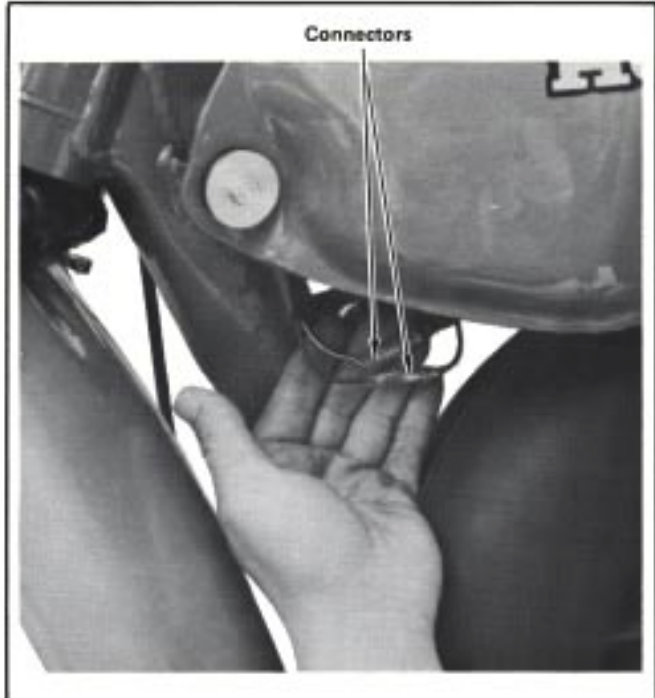

**STEP 54**—Connect ignition switch wires to main wire harness color-to-color.

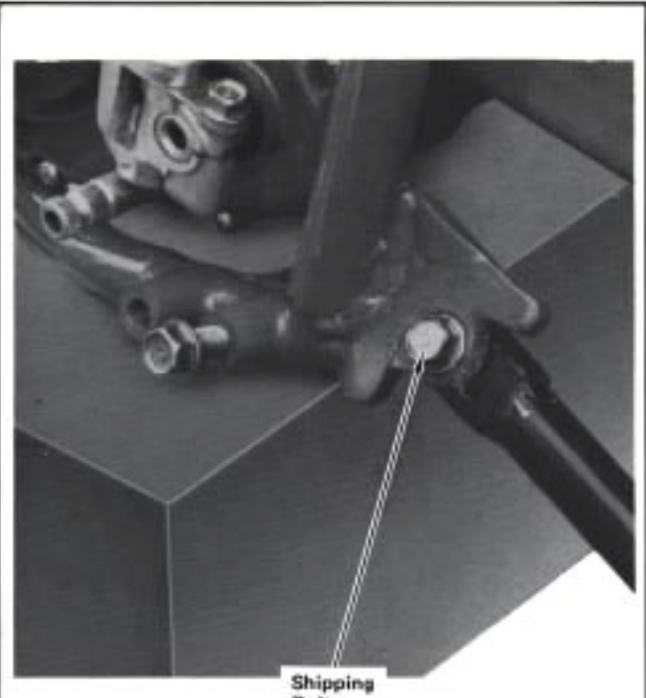

**STEP 55**—Remove 10 mm shipping bolt attaching side stand to frame. Discard bolt.

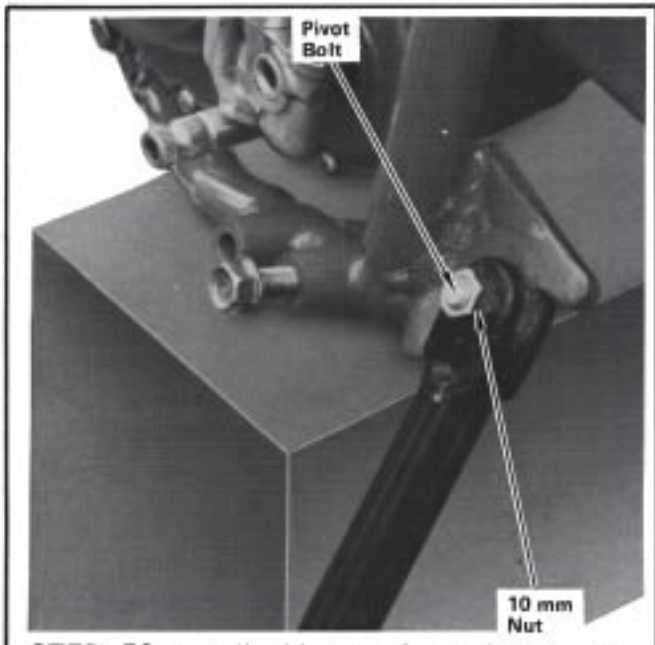

**STEP 56**—Install side stand as shown using special pivot and 10 mm nut. Tighten bolt and nut to specified torque.

**Torque specifications:**

- Pivot bolt: 2–2.5 kg-m (15–18 lbs-ft)
- 10 mm nut: 3–4 kg-m (22–29 lbs-ft)

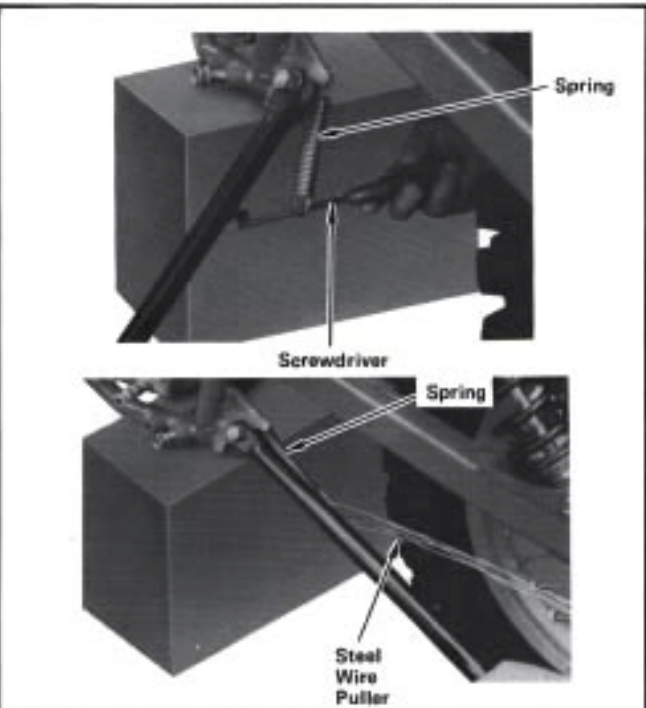

**STEP 57**—Install side stand return spring as shown using a Phillips screwdriver or steel wire. Remove block from under engine and rest motorcycle on side stand.

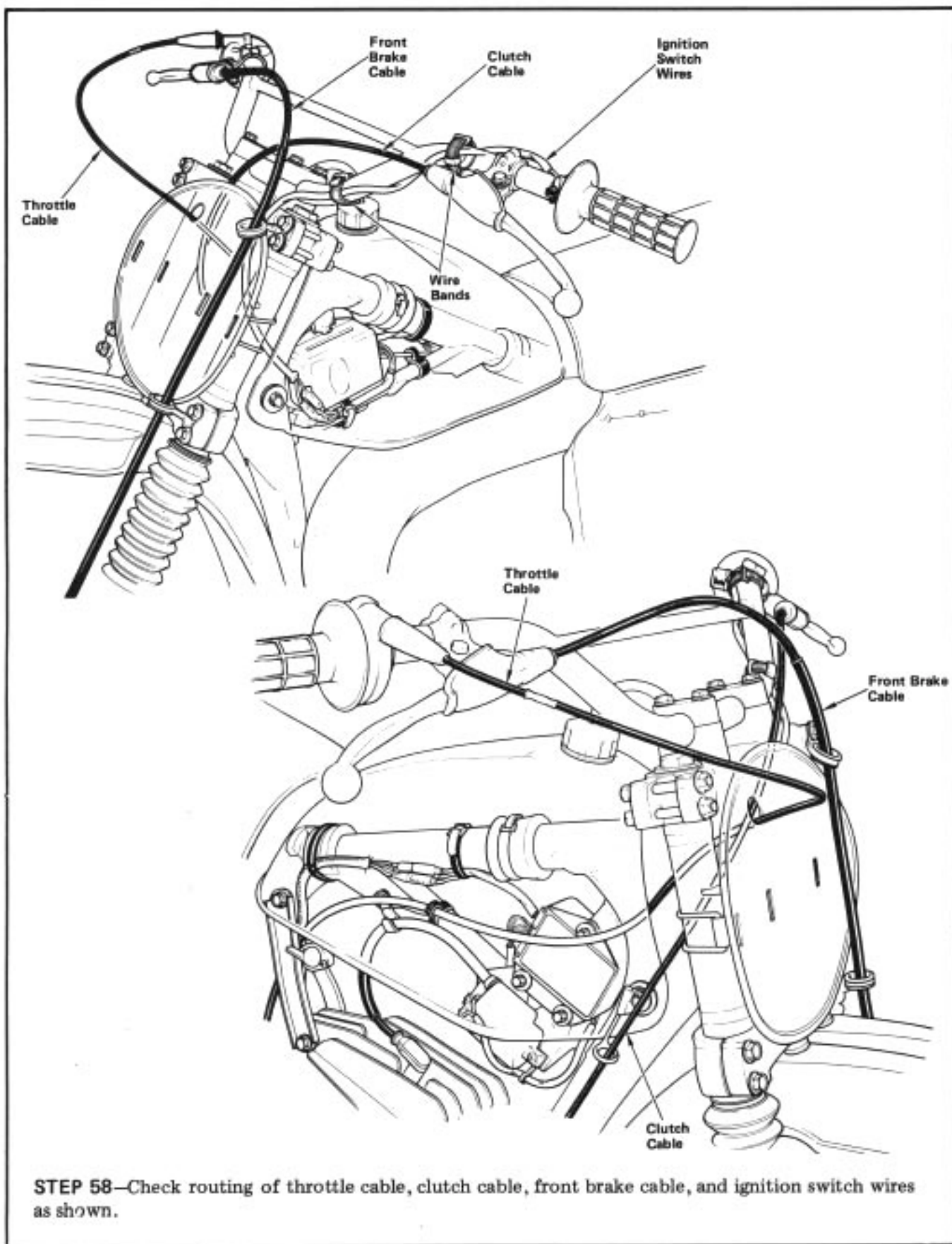

**STEP 58**—Check routing of throttle cable, clutch cable, front brake cable, and ignition switch wires as shown.

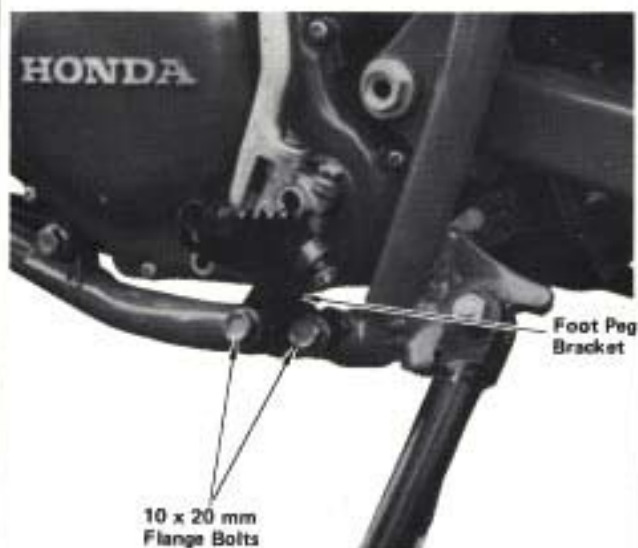

**STEP 59**—Install left foot peg and bracket using two 10 x 20 mm flange bolts (one retained from step 12). Install right foot peg and bracket using 10 x 20 mm bolt retained from step 12. Tighten all foot peg bracket bolts to specified torque.

**Torque specification:**

3.8–4.8 kg-m (28–35 lbs-ft)

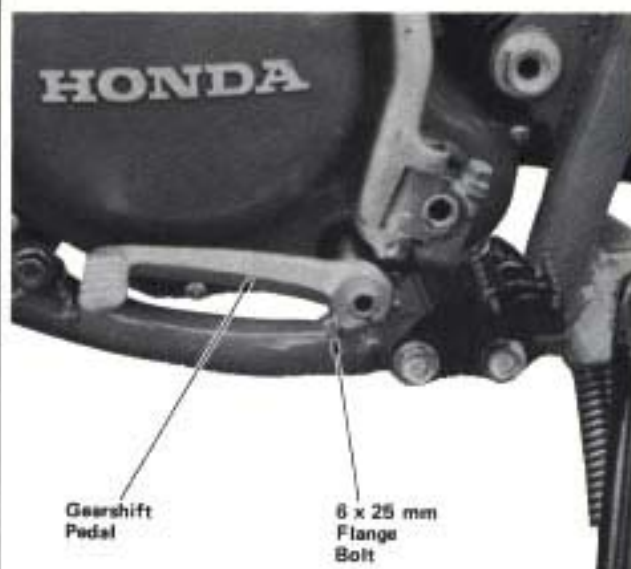

**STEP 60**—Position gearshift pedal so a line between top of pedal and foot peg is parallel with the ground. Install pedal using a 6 x 25 mm flange bolt. Tighten bolt to specified torque.

**Torque specification:**

0.8–1.2 kg-m (6–9 lbs-ft)



**STEP 61**—Remove air cleaner cover from air cleaner case by removing sealing tape. Remove air cleaner element, and clean if necessary. Re-install element and air cleaner cover. Seal cover with tape.

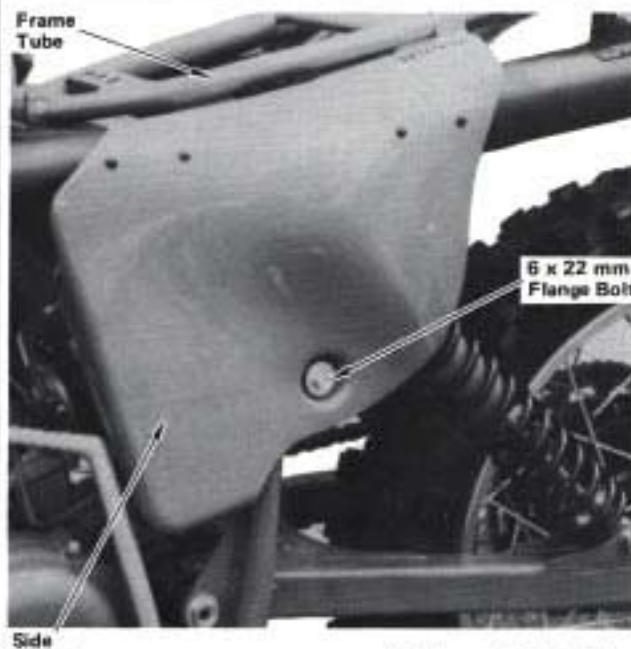

Left Shown, Right Similar

**STEP 62**—Install right and left side covers with upper edges under upper frame tubes as shown. Install a 6 x 22 mm flange bolt through each cover and tighten securely.

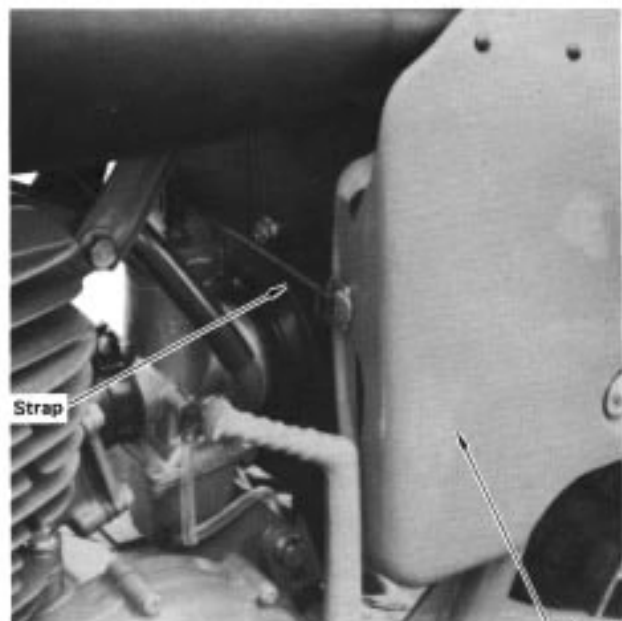

**STEP 63**—Hook a strap to right and left side covers as shown.



**STEP 64**—Turn fuel petcock to OFF and disconnect fuel line at petcock. Remove and inspect fuel tank, drain and flush. Reinstall fuel tank, fill, turn on fuel petcock and check for leaks.

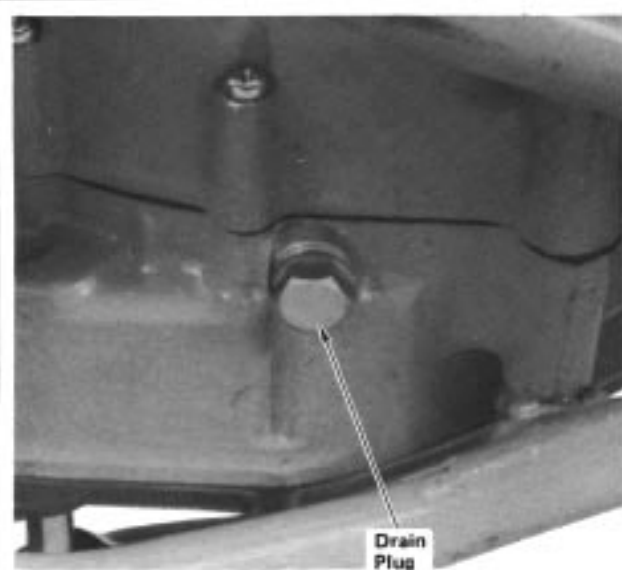

**STEP 65**—Remove drain plug and drain transmission oil. Reinstall and tighten drain plug.

*NOTE: Not required if less than 4 months have elapsed since date of manufacture shown on identification plate on steering head.*

Fill transmission with recommended oil as described in owner's manual.

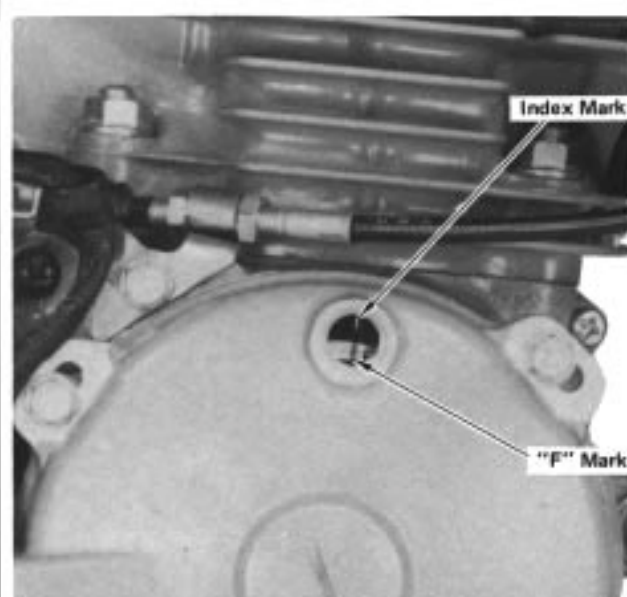

**STEP 66**—Remove inspection hole cap and check ignition timing as described in owner's manual. Reinstall inspection hole cap.

*NOTE: Ignition timing is not adjustable. If timing is incorrect, replace A.C. generator or C.D.I. unit.*

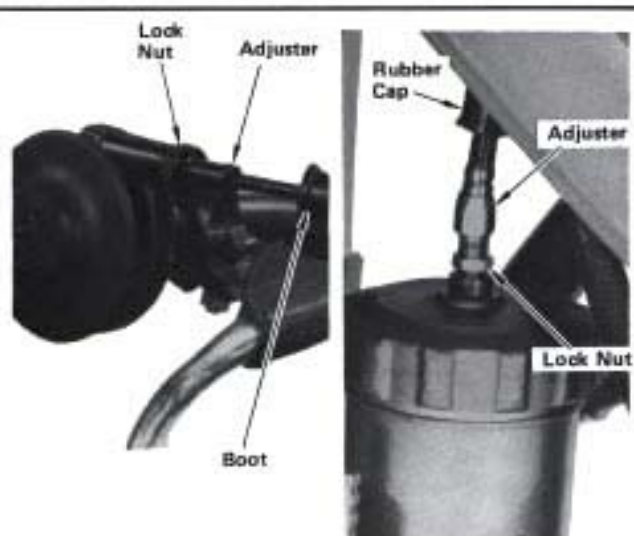

**STEP 67**—Check that throttle grip free play is  $5^{\circ}$ – $10^{\circ}$  of grip rotation. To adjust free play, loosen free play adjusting lock nut and turn adjuster as required. After adjustment, tighten lock nut. Reinstall rubber cap or dust cover.

*NOTE: Free play adjustment can be made at either end of throttle cable. Use lower adjuster to make major adjustments.*



**STEP 68**—Remove 8 x 16 mm bolt attaching submuffler brace to frame. Retain bolt for seat installation.

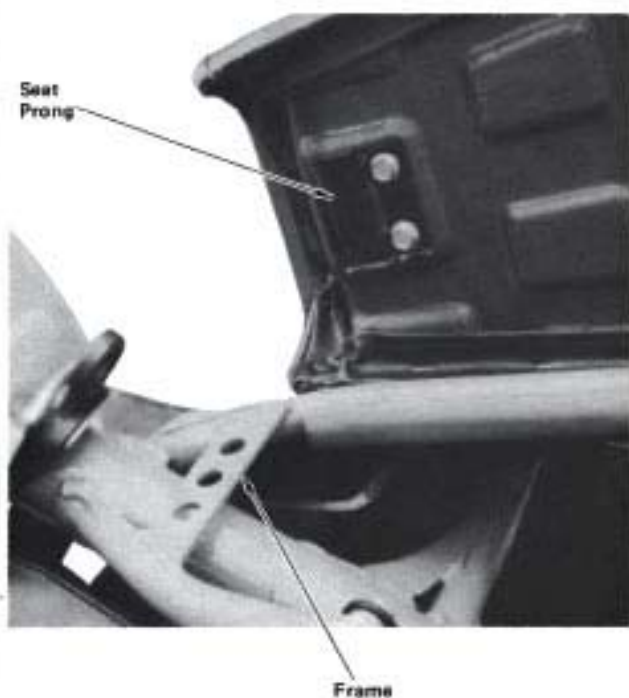

**STEP 69**—Insert seat prong under frame.

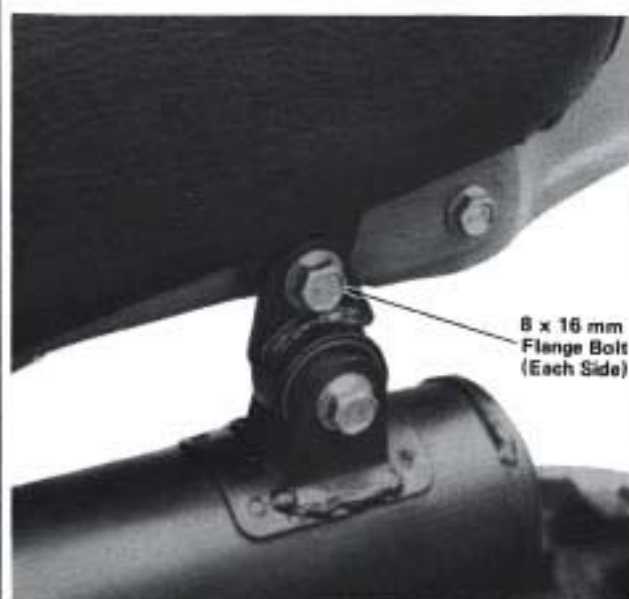

**STEP 70**—Attach rear of seat using an 8 x 16 mm flange bolt on each side. (One of which was retained in step 68.) Tighten bolts to specified torque.

**Torque specification:**

1.8–2.5 kg-m (13–18 lbs-ft)



Adjuster

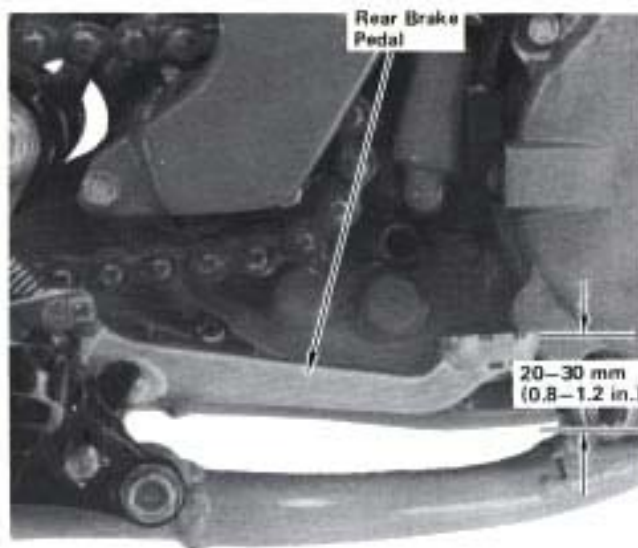

**STEP 71**—Raise rear wheel off the ground using a support block under motorcycle. Rotate rear wheel by hand and measure free play before brake starts to engage. Free play, measured at tip of brake pedal, should be maintained between 20–30 mm (0.8–1.2 in.). To adjust free play, turn adjusting nut. Turning adjusting nut clockwise will decrease free play.

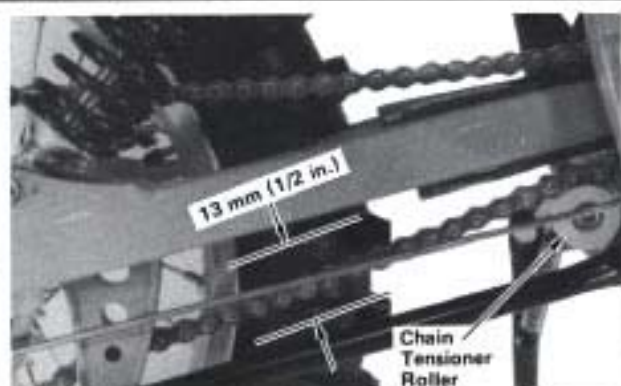

**STEP 72**—Adjust and lubricate drive chain as described in owner's manual. Check alignment of chain guide.

Drive chain slack: 13 mm (1/2 in.)

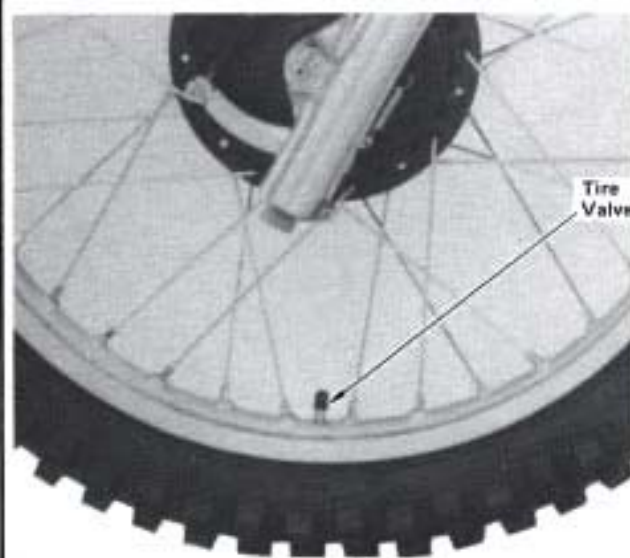

**STEP 73**—Check that spokes are tight. Check tire pressure:

Front: 14 psi.

Rear: 11 psi.

## TORQUE TABLE

ITEM	SIZE	TORQUE
Rear shock absorber bolts	10 mm	3.8-4.8 kg-m (28-35 lbs-ft)
Front fork bolts	8 mm	1.8-2.5 kg-m (13-18 lbs-ft)
Front axle	.....	5.5-7.0 kg-m (40-51 lbs-ft)
Front axle nut	12 mm	5.5-7.0 kg-m (40-51 lbs-ft)
Right fork leg axle clamp bolts or nuts	6 mm	0.8-1.2 kg-m (6-9 lbs-ft)
Front axle lock bolt	6 mm	0.8-1.2 kg-m (6-9 lbs-ft)
Handlebar holder bolts	8 x 35 mm	1.8-2.5 kg-m (13-18 lbs-ft)
Throttle grip housing screws	5 x 20 mm	0.45-0.6 kg-m (3-4 lbs-ft)
Side stand pivot bolt	.....	2-2.5 kg-m (15-18 lbs-ft)
Side stand pivot bolt nut	10 mm	3-4 kg-m (22-29 lbs-ft)
Foot peg bracket bolts	10 x 20 mm	3.8-4.8 kg-m (28-35 lbs-ft)
Gearshift pedal bolt	6 x 25 mm	0.8-1.2 kg-m (6-9 lbs-ft)
Seat attaching bolts	8 x 16 mm	1.8-2.5 kg-m (13-18 lbs-ft)

*NOTE: Check all items listed on the following Pre-Delivery Service Check List. Refer to owner's manual for specifications and detailed procedures. Always test ride the unit to make sure that it is functioning properly.*

## PRE-DELIVERY CHECK LIST

- |   |  |
|---|--|
| <input type="checkbox"/> Adjust front and rear brakes, check cable routing and check operation.                 | <input type="checkbox"/> Check tire pressure. Front: 14 psi; Rear: 11 psi.   |
| <input type="checkbox"/> Adjust clutch, check cable routing and check operation.                                | <input type="checkbox"/> Check operation and adjustment of front and rear suspension.  |
| <input type="checkbox"/> Drain oil from transmission (if necessary). Refill with recommended oil.               | <input type="checkbox"/> Check security of all nuts, bolts, and other fasteners.   |
| <input type="checkbox"/> Remove and inspect fuel tank, drain and flush.   | <input type="checkbox"/> <b>TEST RIDE:</b> Check performance, handling and operation:  |
| <input type="checkbox"/> Reinstall fuel tank, fill, turn on petcock and check for leaks.                        | <ul style="list-style-type: none"> <li>• Transmission and clutch: Ease of shifting, clutch operation, etc.</li> <li>• Acceleration: Smoothness, etc.</li> <li>• Cruising: Smoothness, etc.</li> <li>• Handling: Stability and cornering.</li> <li>• Brakes: Smoothness and stopping power.</li> <li>• Idling: Smoothness, throttle response, return to idle.</li> <li>• Upon completion of test ride, check for fuel and oil leaks.</li> </ul> |
| <input type="checkbox"/> Check ignition timing.   |  |
| <input type="checkbox"/> Check throttle grip free play, cable routing, and operation in all steering positions. |  |
| <input type="checkbox"/> Adjust and lubricate drive chain.  |  |
| <input type="checkbox"/> Check wheel spoke tension.   |  |

## PARTS PACKAGE CONTENTS

The following is a list of items contained in the parts package carton packed in the crate.

DESCRIPTION	H/C	PART NUMBER
Handlebar	-----	-----
Throttle grip	-----	-----
Throttle grip housing A	68060	53167-430-000
Throttle grip housing B	68057	53168-430-000
Handlebar upper holder (2 reqd.)	26524	95014-22200
Screw, pan head 5 x 20 mm (2 reqd.), throttle grip housing	33138	93500-05020-OH
Bolt, flange, 8 x 25 mm (4 reqd.), handlebar upper holders	33829	90111-362-0000
Number plate, front	68070	61136-430-000ZA
Band, number plate (2 reqd.)	68069	61133-430-000
Front fork, right	68016	51400-430-010
Front fork, left	68028	51500-430-010
Front axle	67985	44301-430-000
Nut, flange, 12 mm, front axle	68125	94050-12000
Bolt, flange, 8 x 65 mm (4 reqd.), fork upper bridge	68128	95700-08065-08
Nut, flange, 8 mm (4 reqd.), fork upper bridge	46844	94050-08080
Bolt, flange, 8 x 40 mm (4 reqd), steering stem	34139	95700-08040-08
Brake cable top guide, fork upper bridge	68164	45469-430-000
Brake cable bottom guide, steering stem	67998	45468-430-000
Front fender	68066	61100-430-000
Washer, front fender (4 reqd.)	68102	90506-430-000
Bolt, flange, 6 x 22 mm (4 reqd.)	25228	95700-06022-08
Front brake panel assy	-----	-----
Right side cover	68073	83500-430-000
Left side cover	68076	83600-430-000
Band, side covers	68074	83503-430-000
Bolt, flange, 6 x 22 mm (2 reqd.)	48392	95700-06022-00
Rear shock absorber (2 reqd.)	68045	52400-430-010
Bolt, flange, 10 x 35 mm (3 reqd.), rear shock absorber	68132	95800-10035-08
Bolt, flange, 10 x 50 mm, rear shock absorber (right lower)	68133	95800-10050-08
Side stand	68007	50530-430-000
Screw, pivot, side stand	07871	90108-283-000
Spring, side stand	41425	95014-71702
Nut, hex. head, 10 mm, side stand	68124	94002-10080-OS
Left step assy	68010	50602-430-000
Bolt, flange, 10 x 20 mm (2 reqd.), left step	68129	95700-10020-08
Gearshift pedal	67943	24701-430-000
Bolt, flange, 6 x 25 mm, gearshift pedal	25873	95700-06025-08
Front wheel	-----	-----
Seat	-----	-----
Bolt, flange, 8 x 16 mm (2 reqd.), seat	34764	95700-08016-08
Collar (4 reqd.), front fender	68066	61104-430-000
Owner's manual	68215	3143000